

Acid gas enrichment flow sheet selection

Ralph H. Weiland of Optimized Gas Treating, Inc. and **Tofik K. Khanmamedov** of TKK Company analyse how HIGHSULF™ can produce a Claus plant feed stock of excellent quality even from sour gas streams that would otherwise present disposal problems. HIGHSULF™ is also examined as a means of producing a high quality Claus feed directly from a raw gas such as sulphur plant tail gas. Analysis is carried out by the ProTreat™ amine simulator using the mass transfer rate approach.

Sour gases containing only small concentrations of H₂S, such as those associated with the Burgess shale of North Texas, can present unique challenges because the acid gas produced in the treating plant is sub-quality for Claus sulphur plant feed and cannot be vented or incinerated. Even in plants with a moderate CO₂:H₂S ratio of say 4:1, if complete acid gas removal is necessary (LNG for example), using a single contactor will produce an acid gas stream containing only 20% H₂S. This is too dilute for a conventional Claus plant (Fig. 1).

Sulphur plants are most efficient when operated with a feed containing 55% or more H₂S. The balance of the SRU feed is CO₂ and water, possibly with small amounts of hydrocarbons or other components. Lower concentrations of H₂S result in greater sulphur plant complexity, larger equipment, and higher cost. Streams having less than 32% or so H₂S are near the lower limit for a straight-through Claus process. Such streams cry out for enrichment.

HIGHSULF™ (a trademark of TKK Company) is a general, patented, process strategy¹⁻⁸ that can be applied incrementally in amine treating plants to increase the H₂S concentration in the off-gas from the regenerator and produce an increasingly high quality Claus sulphur plant feed. HIGHSULF technology recognises that the higher the H₂S content of the gas being treated in an amine unit, the greater will be the H₂S concentration in the off-gas from its regenerator. HIGHSULF processing actually takes steps to increase the

H₂S content of the feed gas to the amine plant itself. As a result, the family of HIGHSULF processes produces a more concentrated product stream, as discussed by Khanmamedov¹⁻⁸. One such application is upgrading the acid gas from the main amine plant regenerator to higher H₂S content by processing the regenerator off-gas in another, smaller amine plant. This is termed acid gas enrichment (AGE). It is almost always the case that this secondary treating or AGE unit can very profitably apply HIGHSULF technology.

Within the overall HIGHSULF strategy, there are numerous flow sheet configurations that can be applied to AGE. This article examines several possible processing schemes applied to the enrichment of a very low (8%) H₂S-content gas and to a marginally treatable gas (34% H₂S).

The role of selectivity

AGE depends critically on process selectivity for preferential absorption of H₂S and rejection of CO₂. Attaining the maximum selectivity for H₂S over CO₂ is achieved by using the right solvent under the right process conditions in the right equipment. The perfect process in AGE would remove all the H₂S and none of the CO₂, thereby feeding the Claus plant with pure, wet H₂S. Detailed discussions of selectivity have been presented in many places^{3,4,9,13,14} so only a brief review is given here.

The equilibrium solubilities of H₂S and CO₂ in selective solvents such as methyldiethanolamine (MDEA) do not differ radi-

cally from each other (chemical solvents do not have great inherent thermodynamic selectivity). The differences in absorption rates (the selectivity) are really determined by reaction kinetics and the hydraulic and mass transfer characteristics of the contacting equipment (as expressed by the relative magnitudes of gas- and liquid-side mass transfer coefficients). The mass transfer characteristics of the contacting equipment is a factor that has been largely overlooked by many practitioners, possibly because of poor understanding of separation equipment from the standpoint of its inherent mass transfer rates and what affects them. The effect of reaction kinetics has likewise been misinterpreted and misapplied by others to what remain equilibrium models nonetheless.

MDEA is the most commonly used amine in selective treating. It reacts with H₂S and CO₂ at chemical rates that are at opposite ends of the spectrum. H₂S absorption is accompanied by an instantaneous proton transfer reaction associated with H₂S dissociation and amine protonation. On the other hand, MDEA is non-reactive with CO₂, and CO₂ reacts only very slowly with water to form bicarbonate ion (amine carbamate is not formed). Thus, from a reaction kinetic standpoint, MDEA is highly selective for H₂S.

As devices for carrying out mass transfer, trays and packing (both random and structured) behave quite differently hydraulically and in terms of inter-phase contact. The most obvious reason for this difference is that trays usually have

a continuous liquid phase and dispersed gas phase. The opposite is always true of packing with liquid film flows that are relatively quiescent compared to the highly agitated state of the liquid flowing across trays. Vapour flows are quite turbulent for both trays and packing. Consequently, it is only to be expected that these types of equipment would have different mass transfer characteristics. These differences are decisive in selectivity because the mass-transfer resistance to H₂S absorption is primarily in the gas phase, while for CO₂ it is in the liquid phase. Thus selectivity can be completely controlled by prescribing the relative resistances to mass transfer offered by the two phases through the judicious selection of tower internals and reaction kinetics. Phase resistances are functions of the type (trays, random packing, structured packing) and mechanical details (tray passes, weir heights, packing brand, size, crimp angle, etc.) of the contacting equipment itself as well as the way it is operated hydraulically (flow rates and phase properties that depend on temperature and pressure) and how reaction kinetics affects mass transfer in the liquid.

AGE processes are completely dependent on relative rates of mass transfer. Only a true heat- and mass-transfer-rate based model, such as ProTreat™ (a trademark of Optimized Gas Treating, Inc.), deals directly with the mass transfer characteristics of equipment, and correctly applies chemical reaction kinetics to the calculations, thus providing a realistic chance of reliably predicting performance in a specific piece of equipment. Reliable simulations cannot be done unless the simulation tool itself is cognizant of the mass transfer behaviour of the internals, and the engineer doing the calculations also keeps in mind the hydraulic regime in which the column is operating, e.g., spray versus froth regimes for trays as discussed by Weiland¹⁶.

To summarise, selectivity is a function of the reaction rate of CO₂ with the amine. Because CO₂ does not react with tertiary and sterically-hindered amines, these are the only amine-based solvents that make any sense in highly selective treating applications. Commercially, this makes them the only contenders in AGE, with MDEA (sometimes assisted by partial neutralisation) and the hindered amines as the only realistic candidates. Because the hindered amines currently in commercial use are all

Fig 1: Equilibrium conversion of hydrogen sulphide to sulphur in Claus process

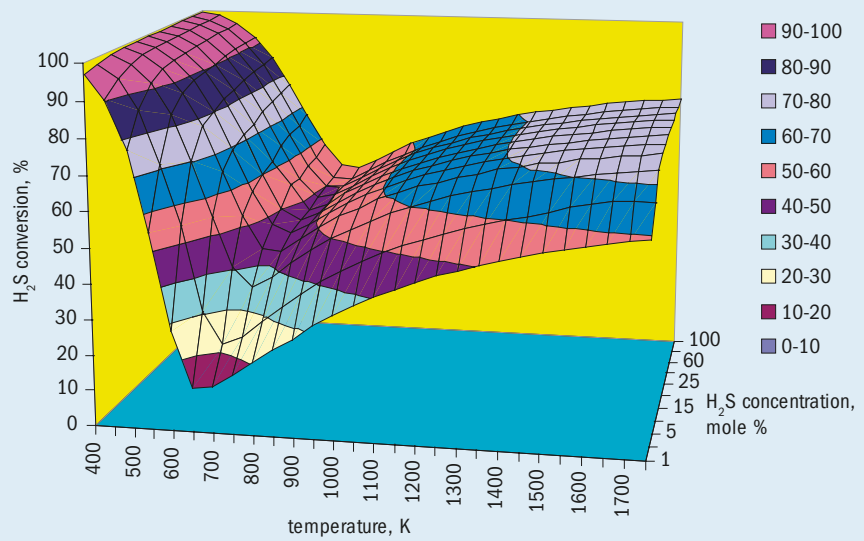

Fig 2: Conventional AGE unit

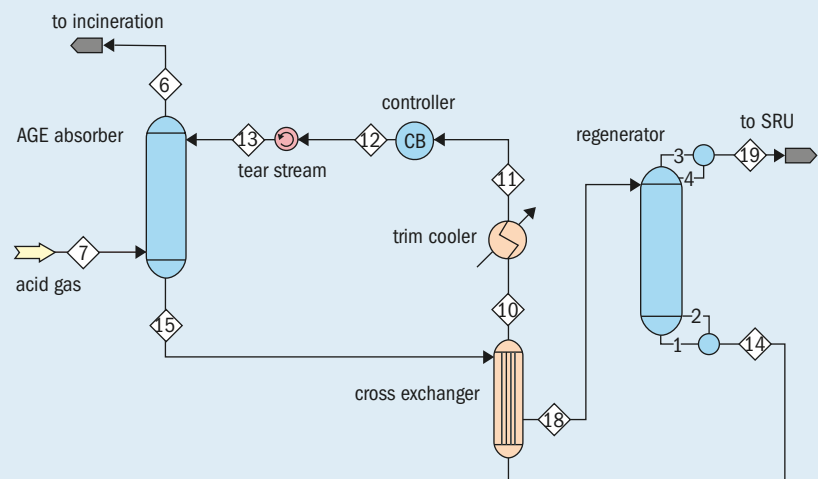

Fig 3: HIGHSULF with combined feeds

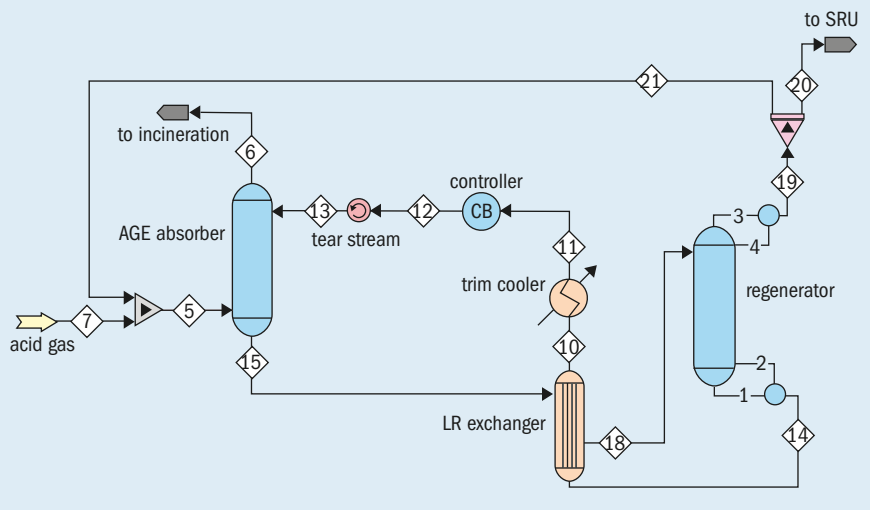

Fig 4: HIGHSULF with separate feeds

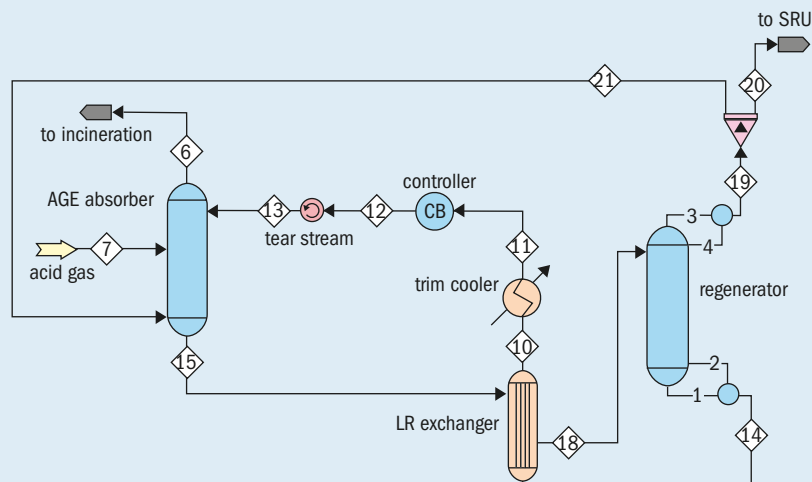
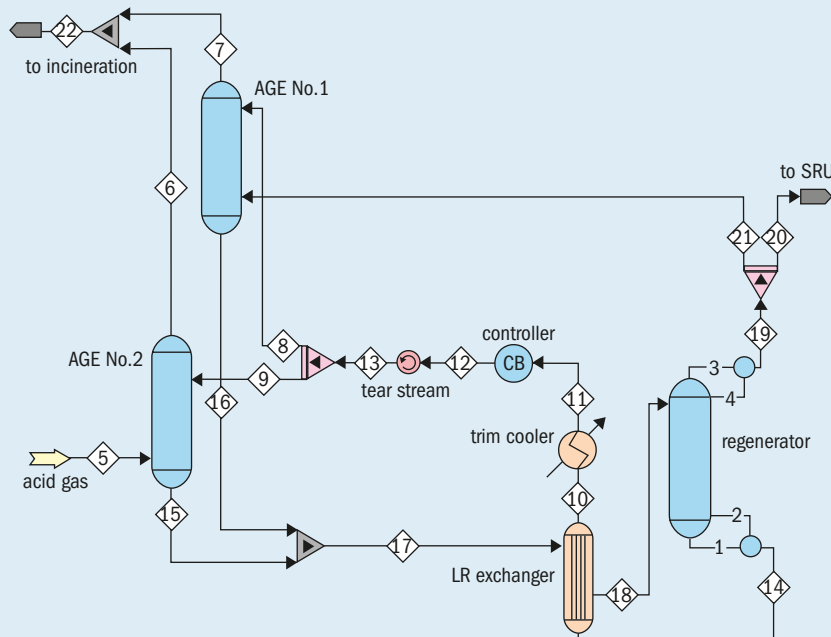

Fig 5: Processing with 2 AGE absorbers



members of the FLEXSORB® family and are proprietary to ExxonMobil Corporation, the remainder of this article focuses on generic MDEA.

Two applications of HIGHSULF™ are considered: upgrading a marginally processable Claus feed (34% H₂S) to super-high quality, and enriching a very low quality (8% H₂S) acid gas to quite acceptable quality.

The purpose is to point out the advantages and disadvantages of several HIGHSULF schemes relative to each other and relative to a completely conventional AGE process flow sheet.

AGE flow sheets

The most common (and least effective) processing scheme for AGE is the conventional flow sheet shown in Fig. 2. The low quality acid gas (H₂S, CO₂ and trace other components) is contacted with selective solvent in the low pressure AGE absorber. This is intended to recover most of the H₂S and reject as much of the CO₂ as possible. The shortcoming of this scheme is that the acid gas feed itself is fixed by upstream processing, whereas, if it could be made to contain more H₂S, the gas to the SRU would automatically be of higher quality.

The flow sheet shown in Fig. 3 is the simplest implementation of the patented HIGHSULF process that permits controlling the effective composition of the AGE unit feed gas.

Depending on the extent to which the HIGHSULF technology is applied, the combined feed to the AGE absorber can be made fairly rich in H₂S, allowing an even richer SRU feed to be produced. An alternative scheme is shown in Fig. 4^{10,11}, where the raw acid gas enters the AGE absorber at an intermediate tray so that the bottom section of the absorber removes the bulk of the recycle H₂S before it joins the low quality acid gas feed.

Mak et al.⁹ proposed another set of processing schemes constructed around the notion of using two absorbers, as shown in Fig. 5. However, in this approach, a separate column is used in an attempt to enrich the already rich SRU feed (AGE No. 1 in Fig. 5). The weak acid gas is enriched in yet another separate operation (AGE No. 2). Thus no advantage is taken of the richer acid gas that could be fed to AGE No. 2 by admixing with a slipstream of SRU feed.

Enriching moderate H₂S acid gas streams

The 25 MMscfd acid gas from a main amine treating unit contains 34% H₂S, 64% CO₂ and 1% each of methane and ethane and is at 15 psig (1 bar) and 120°F (49°C). This is at the lower operability end of a straight-through sulphur plant and can be enriched considerably by treating with MDEA. The solvent used is 3,500 gpm (795 m³/h) of 45 wt-% MDEA at 120°F. All absorbers contain 20 conventional valve trays and are sized for 70% flood. Regenerators contain 30 trays with 120°F condensers. Reboiler conditions are 15 psig and 275 MMBtu/hr duty. The main constraint on all operating schemes is that gas to incineration cannot exceed 75 ppmv H₂S. This is a somewhat arbitrary stipulation but it ensures that comparisons are done under the same requirements.

Conventional amine unit

The conventional scheme (Fig. 2) sets the comparison standard. Under the stated conditions, the ProTreat amine simulation package predicts that enrichment to 62% H₂S (wet basis) is possible, while send-

ing only 40 ppmv H_2S to incineration. At 20 trays, the absorber appears to have more trays than required. This means the H_2S leak is controlled principally by amine lean loading, which is a direct function of reboiler duty but, more importantly, the extra trays are removing CO_2 and diluting the SRU feed gas. When run with ten trays in the AGE absorber, simulation indicates 73% H_2S in the SRU feed and 69 ppmv H_2S in the gas to incineration.

HIGHSULF with combined feeds

HIGHSULF technology endeavours to produce a better quality SRU feed by using part of the SRU feed itself to enhance the H_2S content of the plant's acid gas feed. In its simplest implementation, recycle gas is combined with raw feed. ProTreat simulation predicts that the quality of the SRU feed is a function of the extent of application of the HIGHSULF strategy. Figure 6 shows how the degree of enrichment and the H_2S leak to the stack vary with increasing levels of application of HIGHSULF. As HIGHSULF is applied beyond 65%, the H_2S leak to the stack suddenly escalates because the AGE absorber becomes overloaded and H_2S breaks through into the incinerator gas. However, by the time this happens, the wet SRU feed has reached nearly 82% H_2S . The best a conventional AGE unit could do under identical conditions of flow and energy usage was 72% H_2S . Obviously there is a limit to how vigorously HIGHSULF can be applied before the operation collapses. However, it is remarkable that when the optimal extent of HIGHSULF™ is applied, the SRU feed quality can be increased so much, for zero operating cost, that the dry gas now contains 87% H_2S and only 13% CO_2 .

HIGHSULF with separate gas feeds

The recycled gas is quite a bit higher in H_2S content than the original acid gas stream so the next logical step might be to send the recycle gas to the bottom of the AGE absorber and introduce the acid gas itself part way up the column. In this way the higher CO_2 content of the acid gas has less opportunity to be absorbed into the solvent and reduce its H_2S holding capacity. This kind of scheme corresponds to Fig. 4. Preliminary ProTreat simulations showed that introducing the acid gas below tray 14 from the top in a 20-tray column was almost optimal from the standpoint of keeping the incinerator gas safely below the 75 ppmv maximum allowed. The sim-

Fig 6: How AGE unit performance improves with application of HIGHSULF

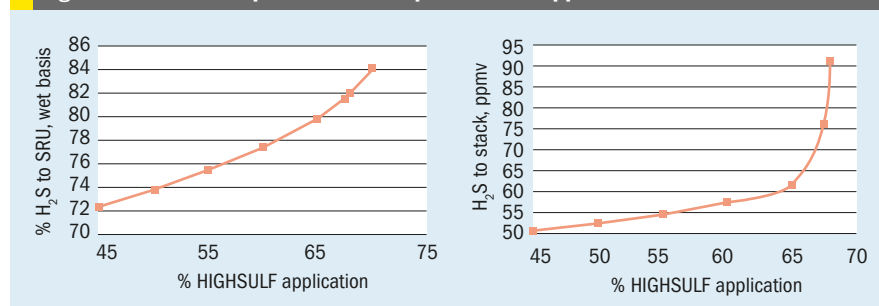

Fig 7: AGE unit performance using HIGHSULF with two gas streams

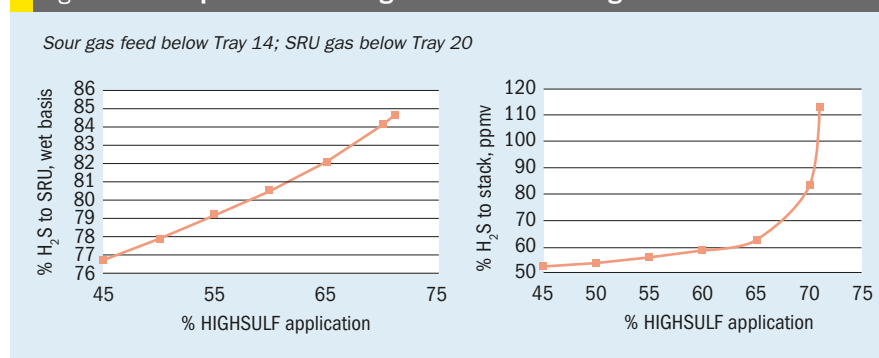
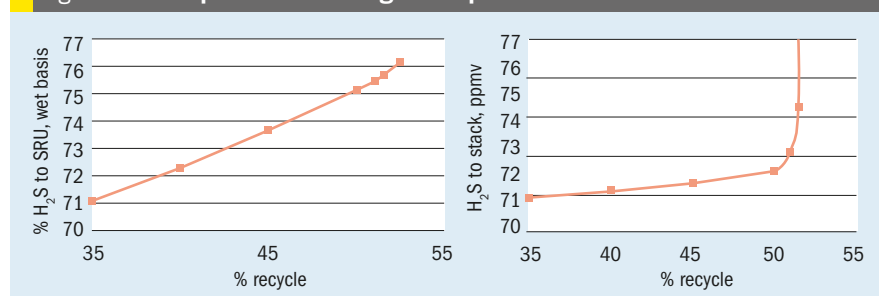

Fig 8: AGE unit performance using two separate AGE absorbers



ulated results plotted in Fig. 7 correspond to acid gas feed below tray 14. There is scarcely any improvement of the two feeds case over the common-feed setup. In this case, therefore, the addition of a second gas-feed nozzle and the associated complication of the special tray arrangement at the mid-tower feed point are not worth the trouble. From a process performance standpoint, the two flow sheets are equivalent, and both produce an extraordinarily high quality Claus plant feed.

Using two AGE absorbers

When two AGE absorbers are used, there is the question of how to split the common solvent flow from the regenerator between them. In the present case, this was done on the basis of equal ratio of solvent flow to H_2S flow in the entering gas streams. Figure 8 shows the effect

of various extents of regenerator acid gas recycled to AGE Absorber No. 1 in Fig. 5. It is immediately evident that this flow sheeting scheme gives inferior processing to HIGHSULF. The reason is that reliance for improved performance has been placed entirely on the recycle gas AGE unit. The acid gas AGE unit is still feeding on the original gas, not a gas whose H_2S content has been in any way enhanced, as it is in HIGHSULF. Therefore, no advantage is being taken of the effect of SRU gas recycle on performance of the acid gas AGE unit. The acid gas AGE unit goes sour because of H_2S breakthrough at only about 51% SRU gas recycle, and at that point, the plant itself is producing only about 75% H_2S in the SRU feed gas. This is still an improvement over conventional AGE, but falls well short of HIGHSULF processing.

Enriching low H₂S acid gas streams

The acid gas flow is the same as in the high H₂S case, 25 MMscfd, but the H₂S content is only 8%, with CO₂ at 90% and methane and ethane making up 1% each. The solvent flow used for all simulations was 1,250 gpm (284 m³/h) at 120°F (49°C). All other conditions are the same as for the high H₂S cases.

ProTreat simulation of a conventional AGE unit with 20 absorber trays suggests an SRU feed upgraded from 8% to 33.7% H₂S (dry basis); however, the absorber is over-trayed so it is picking up too much CO₂ and unnecessarily diluting the SRU feed with excess CO₂. When the same absorber contains only ten trays, the 75 ppmv H₂S specification on the incinerator gas can still be met but the dry-basis H₂S content of the SRU feed rises to 47%. This is a satisfactory feed for a straight through Claus plant.

The maximum application of combined-feed HIGHSULF (Fig. 3) consistent with meeting the 75 ppmv H₂S specification on incinerator gas is about 53%. This gives a dry-basis SRU feed of 54% H₂S, representing about a 15% improvement over a conventional AGE plant. As is the case with treating moderately high H₂S gas, when HIGHSULF is over applied the AGE contactor becomes overloaded and breakthrough occurs. This causes rapid escalation of H₂S in the incinerator gas. However, a 15% improvement over conventional treating can be had for essentially zero operating expense and vanishingly-small capital cost (controller and duct work or pipe).

When the combined feed HIGHSULF configuration is replaced with separate feeds (Fig. 5) for acid gas and recycle gas, Fig. 9 shows that acid gas feed below tray 14 is again close to optimal in terms of minimising H₂S leak from the AGE absorber. With feed to tray 14 and HIGHSULF applied to the maximum extent of about 70%, the SRU dry-basis feed is simulated to contain nearly 71% H₂S. This is an improvement of more than 50% over the conventional AGE unit, and 30% over the combined feed HIGHSULF configuration. The reasons for the significant improvement are twofold. Firstly, by injecting the original acid gas part way up the column, it is exposed to fewer contact trays, so less CO₂ is absorbed. As was seen for conventional AGE, only ten contact trays are needed for optimal enrichment within the constraint of <75 ppmv H₂S leak. In the

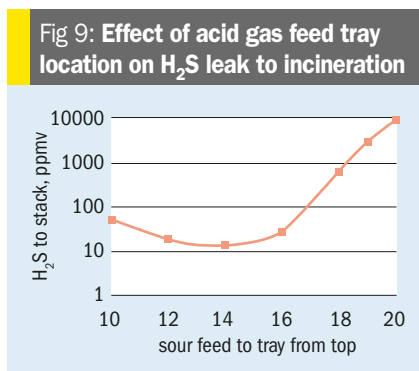

present case, the added H₂S demands a few more trays to meet the same requirement. Second, by removing the bulk of the H₂S on the lower six trays before it mixes with the dilute acid gas stream, the driving force for absorption is kept high and H₂S removal from the recycle gas is faster and more efficient. In essence, the SRU feed is enriched on the lower six trays and the original acid gas is upgraded on the top 14 trays, so in a single column tremendous enrichment can be achieved. The key is nevertheless acid gas recycle as taught by the HIGHSULF patents.

Turning finally to the two absorber configuration, because the same total solvent flow must now be divided between two separate AGE absorbers, it turns out that the percentage of SRU gas that can be reprocessed for enrichment is more limited and that each AGE absorber requires the full 20 trays to meet the <75 ppmv H₂S leak. The enriched SRU feed is only 47% H₂S, no better than a conventional AGE unit operated at maximum selectivity. The problem is the need to divide the solvent flow between the two absorbers and excessive CO₂ pickup in the acid gas treater as a result of it needing additional trays to remove H₂S at a reduced solvent rate.

Concluding remarks

It appears that applying HIGHSULF technology always leads to better AGE unit performance over a conventional AGE plant. Even if higher H₂S content is not required for good sulphur plant operation itself, eliminating CO₂ reduces the gas load on a sulphur plant, thereby increasing its capacity and sulphur recovery level. HIGHSULF provides H₂S-rich feeds in a single step, thereby eliminating the need for separate enrichment. There is almost no operating cost associated with applying HIGHSULF strategy, a minor rerouting of piping is virtually all that is needed to achieve remark-

able increases in SRU feed quality.

Because potentially the entire gas stream can be absorbed, an amine-based AGE unit is quite a severe test of one's ability to model selectivity. Gas flow and composition vary rapidly throughout the contactor, and concentration profiles can become inverted, forming an H₂S bubble within the contactor. The key is mass-transfer rate-based modeling. By being able to simulate amine treating not just in terms of material balances but by analysing the columns as pieces of real equipment with mass transfer taking place within froths on actual trays and films flowing on real packed surfaces, the ProTreat simulator has clearly demonstrated the effectiveness of HIGHSULF technology. ■

References

1. Khanmamedov, T. K., U.S. Patent Number 5,556,606 (Sep 17, 1996).
2. Khanmamedov, T. K., U.S. Patent Number 5,718,872 (Feb 17, 1998).
3. Khanmamedov, T. K., U.S. Patent Number 5,716,587 (Feb 10, 1998).
4. Khanmamedov, T. K., NPRA Q&A Answer Book, V. Energy & Environmental Management, Atlanta, GA, p.14 (1998).
5. Khanmamedov, T. K., National Meeting of Am. Chem. Soc., San Diego, CA (2000).
6. Khanmamedov, T. K., U.S. Patent Number 6,506,349 (Jan 14, w2003).
7. Khanmamedov, T. K., Canada Patent Number 2,204,351 (Sep 17, 2002).
8. Khanmamedov, T. K., PCT/US1995/013768 (Oct 26, 1995).
9. Khanmamedov, T. K., Weiland, R. H., "Upgrading Acid Gas Streams", Sulphur, (Sep-Oct, 2008).
10. Palmer, G., Canada Patent Number 2461952, (Sep 25, 2005).
11. Palmer, G., U.S. Patent Number 7,147,691 (Dec 17, 2006).
12. Mak, J., Nielsen R. B., Chow T., Morgan, O., Wong V., US Patent Number 7,635,408 (Dec 22, 2009).
13. Weiland, R. H., "Acid Gas Enrichment I: Maximizing Selectivity", PTQ Gas (Spring, 2008a).
14. Weiland, R. H., "Acid Gas Enrichment II: Maximizing Selectivity", PTQ Gas (Spring, 2008b).
15. Weiland, R. H., Sivasubramanian, M. S., Dingman, J. C., Laurence Reid Gas Conditioning Conference, Norman, OK (2003).
16. Khanmamedov, T. K., Weiland, R. H., "Top Treatment", Hydrocarbon Engineering (Dec 2010 in press).